

Accessories

item	Model	HSA-2212	HSA-X20	HSA-X23	HSA-X27	HSA-X28	HSA-X32	HSA-X36
1.Full-Enclosed Splash Guard _Multi-piece Door		●	●	●	●	●	●	●
2.Spindle Air Curtain		●	●	●	●	●	●	●
3.Air Blast Through Spindle		●	●	●	●	●	●	●
4.Table Side Air Blast (1 tube)		●	●	●	●	●	●	●
5.Lubrication system		●	●	●	●	●	●	●
6.Fluorescent lampx1		●	●	●	●	●	●	●
7.Spindle Cooler		●	●	●	●	●	●	●
8.Foundation bolt, Concrete		●	●	●	●	●	●	●
9.Portable Chip Bucket		●	●	●	●	●	●	●
10.Screw Type Chip Conveyor		●	●	●	●	●	●	●
11.Oil Fluid Separator		★	★	★	★	★	★	★
12.Cooling System		★	★	★	★	★	★	★
13.Tools package		●	●	●	●	●	●	●
14.Hartford Manual x1		●	●	●	●	●	●	●
15.Auto Power off		●	●	●	●	●	●	●
16.Operation Finish Lamp		●	●	●	●	●	●	●
17.Foot Switch For Spindle Clamp/Unclamp		●	●	●	●	●	●	●
18.Remote Manual Pulse Generator		●	●	●	●	●	●	●
19.RS232 Interface		●	●	●	●	●	●	●
20.Convection Heat Exchanger in Control Box		●	●	●	●	●	●	●
21.Armless Type Tool Magazine(20 pcs)		-	●	●	●	●	●	●
22.6000 rpm Gear Spindle		●	●	●	●	●	●	●
23.CTS Full splash guard with top cover		★	★	★	★	★	★	★
24.Fluorescent Lamp x2		★	★	★	★	★	★	★
25.Link Type Chip Conveyor & Portable Chip Bucket(1 EA)		★	★	★	★	★	★	★
26.Coolant Through Spindle, 20BAR, with Secondary tank		★	★	★	★	★	★	★
27.Coolant Through Spindle, 25BAR, with Secondary tank		★	★	★	★	★	★	★
28.Hydraulic Hose Coolant gun		★	★	★	★	★	★	★
29.Air Gun		★	★	★	★	★	★	★
30.Hartford Manual x2/3		★	★	★	★	★	★	★
31.X/Y/Z-axis linear scale system_HEIDENHAIN		★	★	★	★	★	★	★
32.Without Tool Magazine		★	★	★	★	★	★	★
33.Tool ARM Type Tool Magazine		★	★	★	★	★	★	★
34.10000/12000 rpmDirect Drive Spindle		★	★	★	★	★	★	★
35.NC Rotary Table		★	★	★	★	★	★	★
36.Angular Head(HF-M90L)		★	★	★	★	★	★	★
37.Extend Head (Hartford)		★	★	★	★	★	★	★
38.Multangular Milling Head (HF-MU360L)		★	★	★	★	★	★	★
39.Semi-Automatic Angular Head (HF-S90L)		★	★	★	★	★	★	★
40.Semi-Automatic Multangular Milling Head (HF-SU360L)		★	★	★	★	★	★	★
41.Automatic Angular Head(G.Y)		★	★	★	★	★	★	★
42.Extend Head (GY-E73N or GY-E75N)		★	★	★	★	★	★	★
43.Auto Tool Length Measurement		★	★	★	★	★	★	★
44.Imitative Mold Cutting System		★	★	★	★	★	★	★
45.Speed Inreaser		★	★	★	★	★	★	★
46.DNC Software		★	★	★	★	★	★	★

Standard : ●
Optional : ★



Intelligent Double Column Machining Center

Software *machine*



HSA Series

- Hartrol premium controller
- 5-year warranty on guideways
- Gear type 8,000rpm spindle
- Four linear guideways on Z-axis

HartrolPremium®
From tradition to intelligent

model : HSA-X212

Model : HSA-X23

Electrical features Standard equipment & optional features

Hartrol / standard equipment

- Manual workpiece alignment
- Tool magazine graphics and data display
- Pop-up computer
- Supporting processing parameters
- Lettering processing function
- Tool correction screen & fast tool change function(only suitable for Fanuc)

- Machine utilization rate analysis (only suitable for Fanuc)
- Internal and external thread cutting (only suitable for Fanuc)
- Tool magazine data display-Tool style graphical data display (only suitable for Fanuc)
- Tool life monitoring(only suitable for Fanuc)

Electrical function / Optional features

- Power-off gravity axis lift function
- Coordinate display hand input
- Tool magazine HMI
- Rigid tapping tool retraction
- Spindle thermal displacement compensation

Hartnet / Optional features

- Whole plant utilization rate management system
- Processing countdown management
- Whole plant file transfer system
- Output management

She Hong INDUSTRIAL CO. LTD.

No.3 Jingke N. Road, Taichung City, 408 Taiwan
www.hartford.com.tw Tel: 886-4-23501980 Fax: 886-4-23581793
CAT.No.: 20231113-E09



All Graphic and text on this catalog have been registered. Those who reprint will be held liable.

AI. Applications inside, Hartrol Premium is the control which provides machining status with advanced features.

Imagine what future machines ought to be outlined.

AI Smartcontrol



Hartford redefine the future

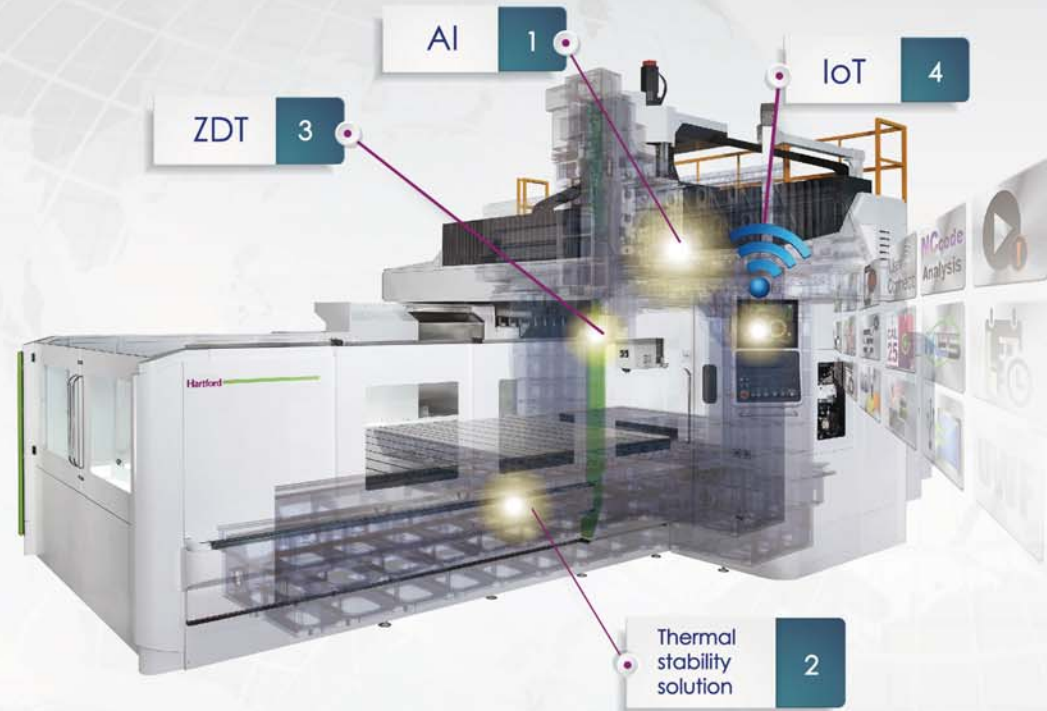

Major functions of Hartford AI controller

- AI Facial Recognition system-Face ID
- AI Environment Thermal Displacement Compensation
- AI Efficient Lubrication Management
- AI Broken Tool Detection System
- AI Highlight on Intelligent Auger
- AI Navi

<p>IoT</p> <ul style="list-style-type: none"> + Hartrol Premium Sync & Update + User Connect 	<p>Thermal stability solution</p> <ul style="list-style-type: none"> + Spindle Thermal Compensation + Casting Thermal Compensation + Thermal Symmetry / Thermal Balancing
<p>ZDT</p> <ul style="list-style-type: none"> + Diagnosis Report on Spindle Operation + Alarm Report System 	<p>AI</p> <ul style="list-style-type: none"> + Facial Recognition System + AI Efficient Lubrication Management + Smart Efficient Chip Collection

The very first step for fully intelligent machining.

Hartford APP Store

What is Hartrol Premium?

Hartrol premium is a brand new intelligent controller Hartrol , Hartnet and Hartford electrical function together which developed and made by Hartford.

HMI and operation is user friendly, it can achieve :

1. Internet connection, collect and analyze data, monitoring by portable device
2. Intelligent control: Auto revise human error and operating basis
3. Real time update new APPs

The difference between Hartrol plus and others

Function	Hartrol Premium 	Others
Screen Size	19" Multi-touch Panel	10.4" (OPT:15")
Look Ahead Block	2700(G5P20000)	400(1000 Max.)
Hard Drive	32GB SSD	NO
Smoothing Interpolation	SSS 4G	Option
Industry 4.0	Hartford UserConnect	NO



The main technologies of Hartford smartcenter include intelligent managing system, status monitoring, alarm predicting, machine status diagnosis, crash preventing, 3D program simulation, machining efficiency improving...etc. All the intelligent functions help you control the machine status and assure the job quality.



EXCLUSIV 
Hartrol Plus APP

The Intelligent Controller You Should Have

With three major solutions, Hartrol Premium takes you machining to the next level. Highly optimized and intelligent controls bring even more capabilities and productivity to your metal cutting processes. With ease use, advanced automation, and smart data collection, Hartrol plus is essential tool for enhancing performance on your production floor.



Hartford UserConnect

- Alert Notification
- Remote Diagnoses
- Remote Value Enhancement
- Remote Monitoring & Management

Hartford smartcenter APP



The functions mentioned above will need to option the Hartrol premium controller or Dual screen with Fanuc controller.

AI Tool breakage detection (opt.)

Available with tool size 6mm above

- Tool wears when electric current ratio increased
- When tool abrasion over than your setting, machine alarms to avoid tool breakage



Highlight on Intelligent Auger(opt.)

50% efficiency increases

- Intelligent auger automatically proceeds cleaning iron chips based on electrical current of spindle.
- Intelligent auger automatically performing reversal mode in case amount of iron chips outnumbers, preventing from machine stop.
- Auger is overly shielded



What Hartford APP can do for you?

AI Environment Thermal Displacement Compensation(opt.)

Vertical machining center : **0.03mm**

Thermal displacement problem is improved up to **60%**
It can achieve good accuracy as in constant temperature room.



AI Efficient Lubrication Management (opt.)

50% lubrication saved.

- Auto-adjustment oil supply base on machining condition.
- 50% oil consumption saved



AI Facial recognition system (opt.)

Face ID log-in authority
Recognition time: **2 seconds**
Recognition accuracy: **100%**



Set & Inspect(opt.)

Graphical user interfaces for part setting, inspection, tool setting

- Ease of use
- Increasing usability
- Eliminating manual set-up tasks
- Increasing efficiency



CIS Integral Design page



Hartford ZDT

Eliminate machine down time and increase efficiency. ZDT -

- Ease of use
- Check parts status clearly
- Eliminating unexpected down time
- Instand notification to your machine and your portable device



Spindle Vibration Intelligent Monitoring System (B-Safe) is ensuring spindle stability at times(opt.)

Highlights

- APP Vibration function is handy to set up manually.
- Alert status on crash protection.
- Responsive graphic is available for diagnosis by user, and analytic information is just-in-time served.



Strong cutting force; release your production potential

All New Infinity of high rigidity, high-precision can help you machine blank to become the finished mold of excellent precision and smoothness.



Actual Cutting Test

Model: HSA-428

- Spindle: 6,000 rpm Gear type, 26kW
- Cutting material : S45C



Face milling

Tool diameter Ø125 mm
Feed rate 2,050 mm/min
Cutting depth 4 mm
Cutting width 100 mm
Cutting volume 820 cc/min



End milling

Tool diameter Ø63 mm
Feed rate 1,350mm/min
Cutting depth 40 mm
Cutting width 10 mm
Cutting volume 540 cc/min



Tapping

Tool diameter M36 x P4 mm
Feed rate 480 mm/min
Cutting depth 40 mm
Spindle speed 120rpm



Drilling

Tool diameter Ø53 mm
Feed rate 100mm/min
Cutting depth 50 mm
Spindle speed 400rpm

ALL NEW INFINITY, from roughing to finishing, allows you to accomplish at one go

The brand-new HSA series brings you the best processing performance and ultimate precision. At the same time, it incorporates a self-developed manual head-changing mechanism with the HSA architecture, achieving a five-axis machining model. This unique machine structure design caters to various types of processing needs.

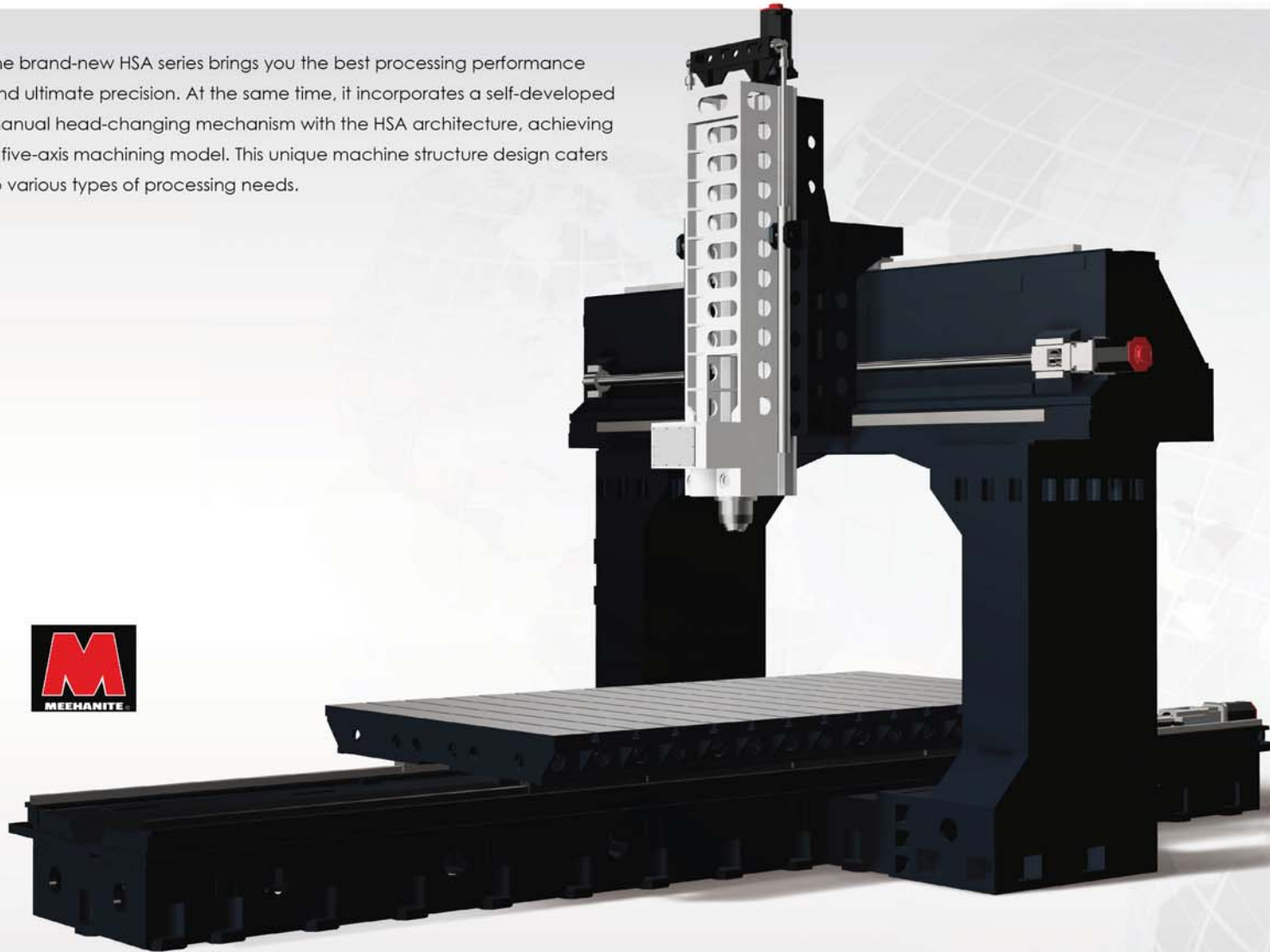

Full range of linear guideway five-year warranty

Warranty coverage will not apply under following conditions

- 1.Improper operation(collison)
- 2.Lack of regular cleaningof accumulated debris causing damage to the linear rails &carriages.



Z-axis four linear guideways three binding structure patented technology

The patented HSA four linear guideways three binding structure technology, two-way support provides high rigidity while cutting, bringing you excellent performance.
Patent No.1264343 machining center Z-axis head Z-axis four linear guideways.



HSA three-axis direct-connected drive advantage

HSA series X-axis and Y-axis pair up with the planetary reducer, effectively enhancing the overall axial drive torque of the machine.

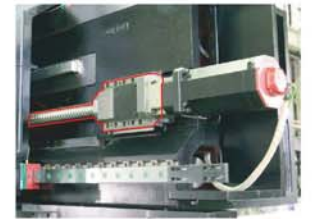

X-axis three linear guideways design

HSA-X28/HSA-X32/HSA-X36

The X-axis three linear guideways design can be used to resist process rotation torsion and enhance rigidity by more than 50%. Moreover, the maximum load of a workbench can be 30,000kg, thus allowing you to meet your processing needs and help you each your accuracy and quality requirements.

(HSA-X20 / X23 / X27 / X212 are two linear guideways.)



Unique Machine Structure Design

Screw support mechanism maintains excellent positioning accuracy

- In time of the transmission of the X and Y axes, ensure that power is maintained.
- Improve screw dead weight sagging; enhance the positioning accuracy and life of screw.

Model above the 5 meters X-axis is standard configuration; below 4 meters is optional configuration.

Y-axis support mechanism, X36 is standard configuration.

Y-axis support mechanism, X23/X27/X28 is optional configuration.



X-axis screw support mechanism

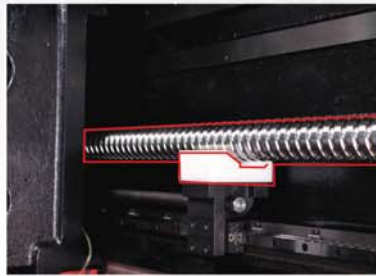

Y-axis screw support mechanism

Diversified strong spindle meets your processing needs



Hartford made gear type 8,000 rpm Two-stage spindle (optional feature)

- To follow the process attribute, pair up with high or low gear.
- Spindle-mounted structure design
- Thermal separation technology enables thermal extension to control and apply to HAS-X20 / X23 / X27 / X28 / X32 / X36

◀ Hartford made gear type 8,000 rpm Two-stage spindle (optional feature)



3

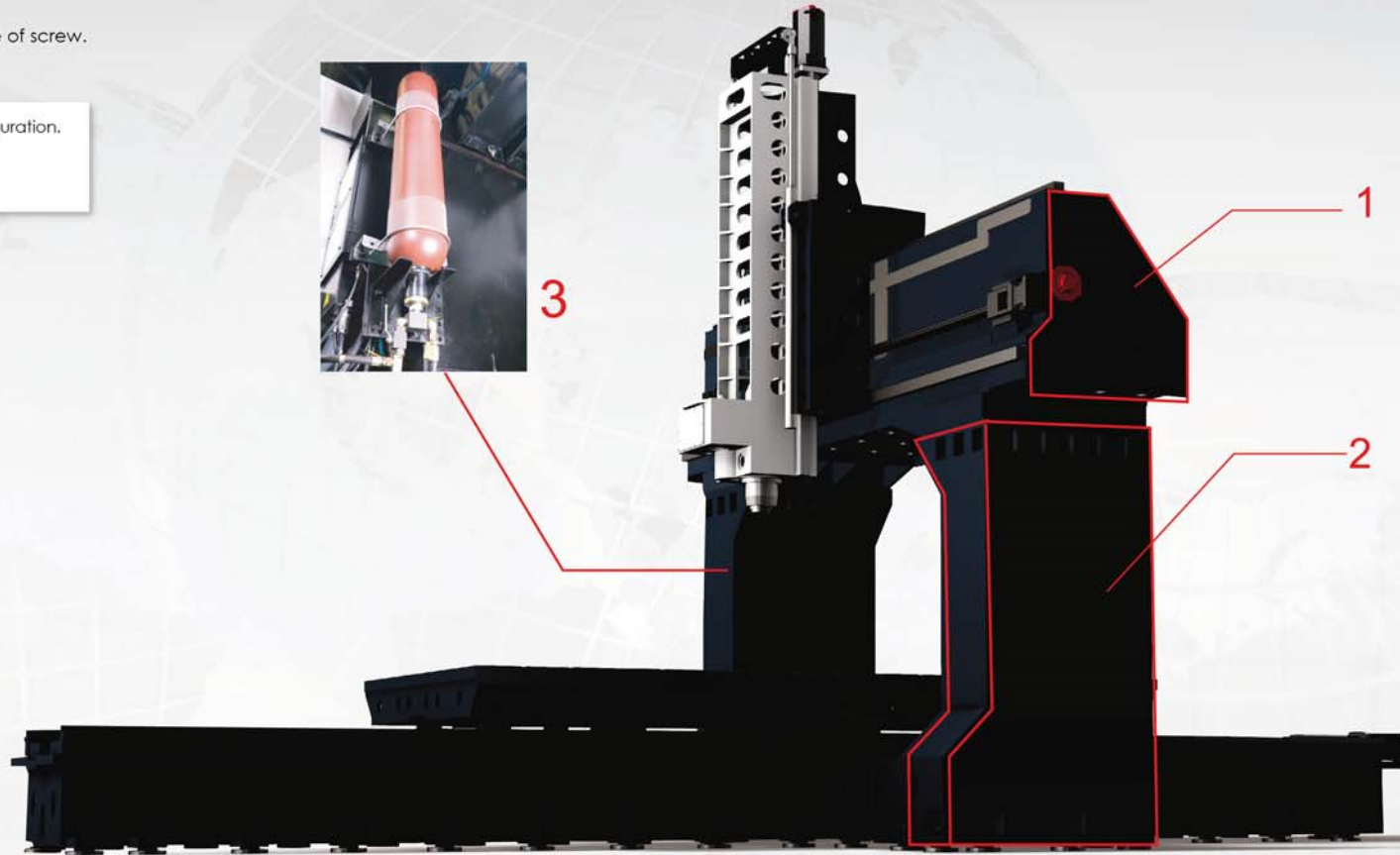

1. The new slant beam design effectively reduces vibration from cutting

- Reduce the vibration generated by the process.
- Enhance accuracy and surface sheet cleanliness during processing.

Patent :
M435318 Beam rear slant design

2. Extra-large columns effectively transfer the maximum cutting force

- The joint width between bottom of the column and the base is increased to 1,250mm
- Reduce overall vibration from cutting.

Patent:
M437316 Structure section has design to resist torsion.
M438938 Column foot span design

3. Z-axis nitrogen accumulator weight system(OPT.)

- Reduce operating noise of hydraulic tank.
 - Reduce hydraulic tank oil temperature by 50%
 - Effective energy-saving more than 20%
- Suitable for HSA-X23/X27/X28/X32/X36 full range of models.

The Y-axis is designed to bring a broader range of processing

ALL NEW INFINITY series models providing increased Y-axis travel design, you can upgrade you range of processing through the increase of Y-axis travel. We have achieved our purpose to process the widest range with the minimum cost.

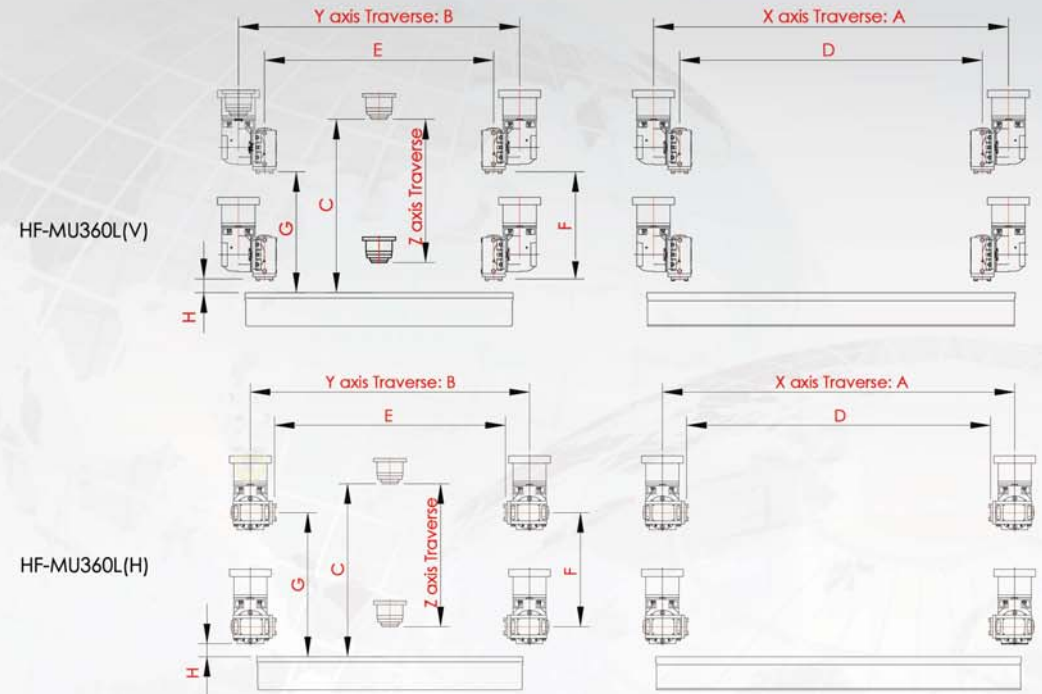
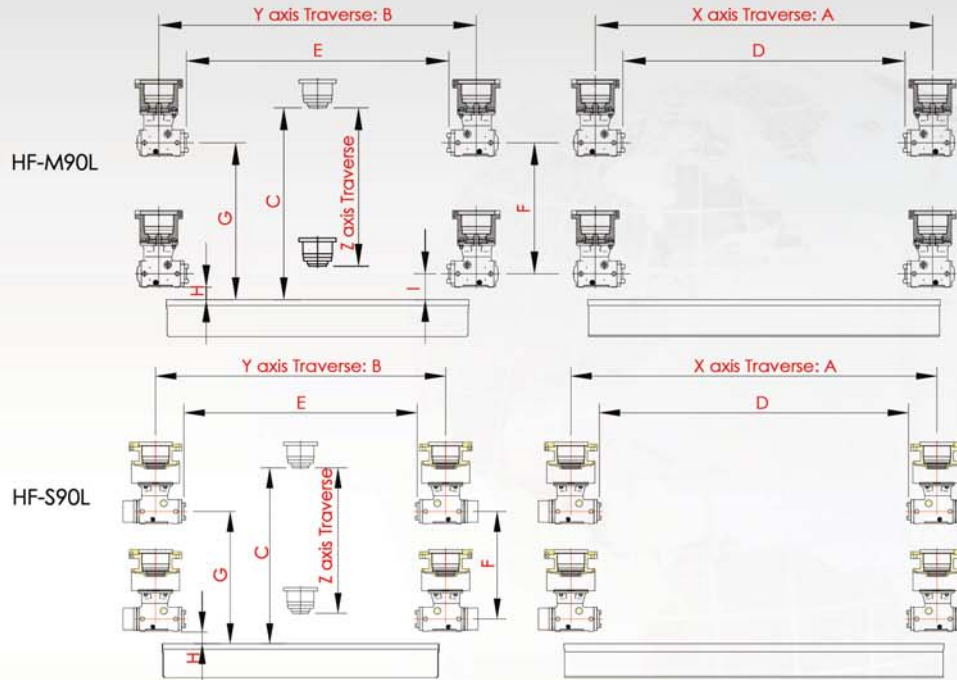

Model	Z-TRAVEL	COLUMN-HIGH	A	B	C	HF-M90L / S90L														
						D		E		F		G		H	I					
						M90L	S90L	M90L	S90L	M90L	S90L	M90L	S90L							
HSA-320			3000	2000		2636	2588	1636	1588											
HSA-420			4000	2000		3636	3588	1636	1588											
HSA-323	780	1900	3000	2300	980	2636	2588	1936	1888	602.5	517	743.5	658							
HSA-423	780	2000	4000	2300	1080	3636	3588	1936	1888	702.5	617	843.5	758							
HSA-523	1000	2200	5000	2300	1280	4636	4588	1936	1888	902.5	817	1043.5	958							
HSA-327	1200	2400	3000	2700	1480	2636	2588	2336	2288	1102.5	1017	1243.5	1158							
HSA-427			4000	2700		3636	3588	2336	2288											
HSA-527			5000	2700		4636	4588	2336	2288					50	141					
HSA-627			6000	2700		5636	5588	2336	2288											
HSA-428			4000	2800		3636	3588	2436	2388											
HSA-528			5000	2800		4636	4588	2436	2388											
HSA-532	780	2000	5000	3200	1040	4636	4588	2836	2788	662.5	577	803.5	718							
HSA-632	1000	2200	6000	3200	1240	5636	5588	2836	2788	862.5	777	1003.5	918							
HSA-536	1200	2400	5000	3600	1440	4636	4588	3236	3188	1062.5	977	1203.5	1118							
HSA-636			6000	3600		5636	5588	3236	3188											
HSA-736			7000	3600		6636	6588	3236	3188											
HSA-836			8000	3600		7636	7588	3236	3188											

Model	Z-TRAVEL	COLUMN-HIGH	A	B	C	HF-MU360L(V/H)															
						D		E		F		G		H							
						V	H	V	H	V	H	V	H	V	H						
HSA-320			3000	2000		2610	2636	1610	1636												
HSA-420			4000	2000		3610	3636	1610	1636												
HSA-323	780	1900	3000	2300	980	2610	2636	1910	1936	511.5	564.5	561.5	743.5							50	
HSA-423	780	2000	4000	2300	1080	3610	3636	1910	1936	611.5	780	661.5	843.5							63.5	
HSA-523	1000	2200	5000	2300	1280	4610	4636	1910	1936	811.5	864.5	861.5	1043.5							50	
HSA-327	1200	2400	3000	2700	1480	2610	2636	2310	2336	1012	1064.55	1062	1243.5							50	
HSA-427			4000	2700		3610	3636	2310	2336												
HSA-527			5000	2700		4610	4636	2310	2336												
HSA-627			6000	2700		5610	5636	2310	2336												
HSA-428			4000	2800		3610	3636	2410	2436												50
HSA-528	780	2000	5000	2800	1040	4610	4636	2410	2436	571.5	624.5	621.5	803.5								
HSA-532	1000	2200	5000	3200	1240	4610	4636	2810	2836	771.5	824.5	821.5	1003.5								
HSA-632	1200	2400	6000	3200	1440	5610	5636	2810	2836	971.5	1024.5	1022	1203.5							50	
HSA-536			5000	3600		4610	4636	3210	3236												
HSA-636			6000	3600		5610	5636	3210	3236												
HSA-736			7000	3600		6610	6636	3210	3236												
HSA-836			8000	3600		7610	7636	3210	3236												

The Y-axis is designed to bring a broader range of processing

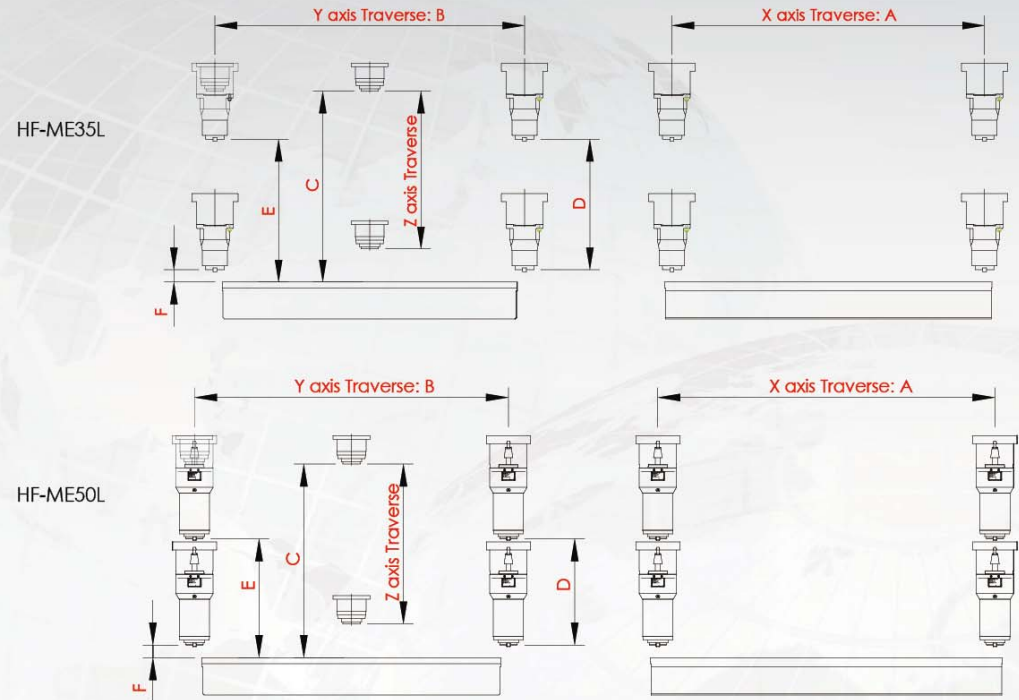
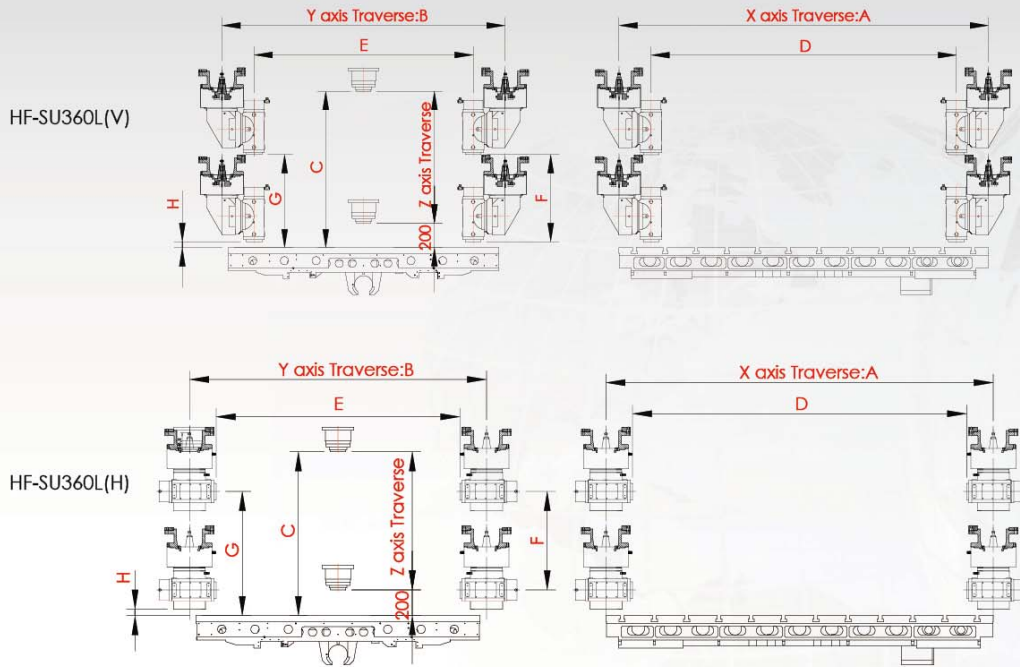

HF-SU360L(V/H)

Modle	Z-TRAVEL	COLUMN-HIGH	A	B	C	D		E		F		G		H	
						V	H	V	H	V	H	V	H	V	H
HSA-320			3000	2000		2480	2588	1480	1588						
HSA-420			4000	2000		3480	3588	1480	1588						
HSA-323	780	1900	3000	2300	980	2480	2588	1780	1888	416	472	466	672		
HSA-423	780	2000	4000	2300	1080	3480	3588	1780	1888	516	572	566	772		
HSA-523	1000	2200	5000	2300	1280	4480	4588	1780	1888	716	772	766	972		
HSA-327	1200	2400	3000	2700	1480	2480	2588	2180	2288	916	972	966	1172		
HSA-427			4000	2700		3480	3588	2180	2288						
HSA-527			5000	2700		4480	4588	2180	2288						
HSA-627			6000	2700		5480	5588	2180	2288					50	50
HSA-428			4000	2800		3480	3588	2280	2388						
HSA-528	780	2000	5000	2800	1040	4480	4588	2280	2388	476	532	526	732		
HSA-532	1000	2200	5000	3200	1240	4480	4588	2680	2788	676	732	726	932		
HSA-632	1200	2400	6000	3200	1440	5480	5588	2680	2788	876	932	926	1132		
HSA-536			5000	3600		4480	4588	3080	3188						
HSA-636			6000	3600		5480	5588	3080	3188						
HSA-736			7000	3600		6480	6588	3080	3188						
HSA-836			8000	3600		7480	7588	3080	3188						

HF-ME35L / HF-ME50L

Modle	Z-TRAVEL	COLUMN-HIGH	A	B	C	D		E		F
						ME35L	ME50L	ME35L	ME50L	
HSA-320			3000	2000						
HSA-420			4000	2000						
HSA-323	780	1900	3000	2300	980	580	430	630	480	
HSA-423	780	2000	4000	2300	1080	680	530	730	580	
HSA-523	1000	2200	5000	2300	1280	880	730	930	780	
HSA-327	1200	2400	3000	2700	1480	1080	930	1130	980	
HSA-427			4000	2700						
HSA-527			5000	2700						
HSA-627			6000	2700						50
HSA-428			4000	2800						
HSA-528	780	2000	5000	2800	1040	640	490	690	540	
HSA-532	1000	2200	5000	3200	1240	840	690	890	740	
HSA-632	1200	2400	6000	3200	1440	1040	890	1090	940	
HSA-536			5000	3600						
HSA-636			6000	3600						
HSA-736			7000	3600						
HSA-836			8000	3600						

The Y-axis is designed to bring a broader range of processing

QC cutting ability test present the beat quality of Hartford

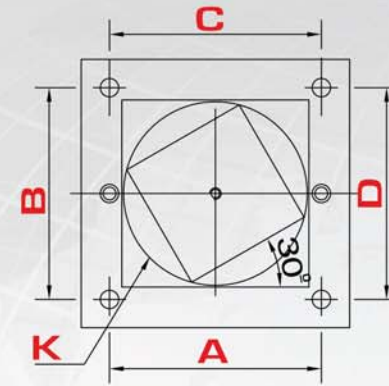
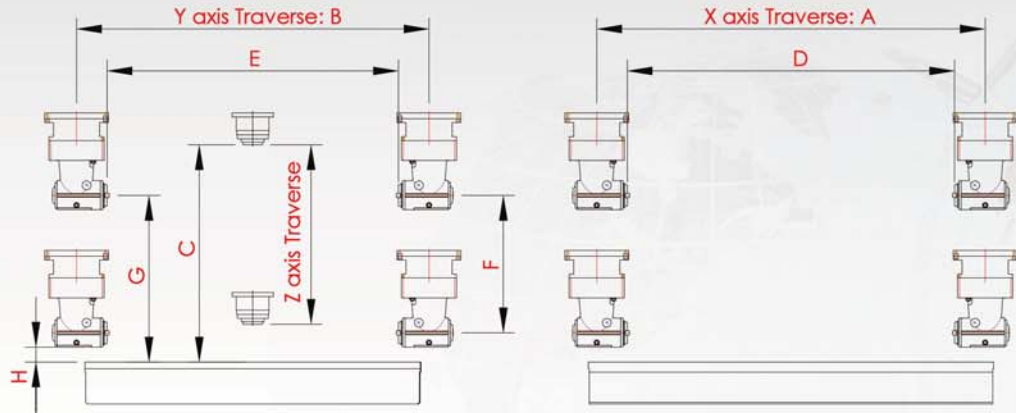

HSA-423 Mold Testing

- Test materials : F25C
- Cutting speed : F200-500
- Spindle speed : S500-800
- Test tool diameter : $\phi 25\text{mm}$

Positioning machining precision
Positioning accuracy

	A	B	C	D	K
Error value	0.020	0.020	0.020	0.020	0.015
Actual value	0.0016	0.0015	0.0070	0.0019	0.0037
	(\oplus)	(\oplus)	(\oplus)	(\oplus)	(\ominus)

unit(mm)

Through FIG cutting accuracy
Precision through FIG.

Accuracy	Error value	The actual value
The true flatness of bed top surface(X/Y-axis)	1000 ∇ 0.05/M, 1000-2000 \blacktriangle 0.06/M, 2000 0.07/M	0.02
Right angle of mutual movement of each axis(X/Y-axis)	0.020/500	0.005
Right angle of mutual movement of each axis(Y/Z-axis)	0.02/500	0.005
Slanting swing in spindle hole	Fixed Side : 0.005, Free Side : 0.015/300	0.001/0.005
Accuracy through roundness	0.012/150[X-axis 5000以上 0.020/150]	0.003

GY_automatic 90 degree head _N75

Model	Z-TRAVEL	COLUMN-HIGH	A	B	C	D	E	F	G	H
HSA-320			3000	2000		2636	1636			
HSA-420			4000	2000		3636	1636			
HSA-323	780	1900	3000	2300	980	2636	1936	543	678	
HSA-423	780	2000	4000	2300	1080	3636	1936	643	778	
HSA-523	1000	2200	5000	2300	1280	4636	1936	843	978	
HSA-327	1200	2400	3000	2700	1480	2636	2336	1043	1178	
HSA-427			4000	2700		3636	2336			
HSA-527			5000	2700		4636	2336			
HSA-627			6000	2700		5636	2336			50
HSA-428			4000	2800		3636	2436			
HSA-528	780	2000	5000	2800	1040	4636	2436	603	738	
HSA-532	1000	2200	5000	3200	1240	4636	2836	803	938	
HSA-632	1200	2400	6000	3200	1440	5636	2836	1003	1138	
HSA-536			5000	3600		4636	3236			
HSA-636			6000	3600		5636	3236			
HSA-736			7000	3600		6636	3236			
HSA-836			8000	3600		7636	3236			

unit : mm

2. Manual position head (manually fixed) applicable to general model HSA



Universal head (manual/semi-automatic)		Manual universal head	Semi-automatic universal head
A-axis : $\pm 110^\circ$, C-axis : $\pm 180^\circ$ Maximum speed: 2,500rpm Maximum power: 18.5kw The maximum torque to withstand: 650N-m	Binding mechanism	Manual	Manual
	Unclamping mechanism	Manual	Automatic
	C-axis rotation	Manual	Manual



90° side milling head (manual / semi-automatic)		Manual 90° head	Semiautomatic 90° head
Manual tool change (manual / hydraulic lock release tool.) Maximum speed: 2,000rpm Maximum power: 18.5kw The maximum torque to withstand: 650N-m	Binding mechanism	Manual	Manual
	Unclamping mechanism	Manual	Automatic
	C-axis rotation	Manual	Manual



Extension head (350/500mm)
Maximum speed : 4,000rpm Maximum power : 18.5kw The maximum torque to withstand : 650N-m

A variety of Harfford made spindles have Quality assurance

Torque curve diagram

- 6,000 rpm gear type spindle
- 8,000rpm gear type spindle(optional configuration)
- 12,000rpm direct-connected spindle(optional configuration)

Direct type

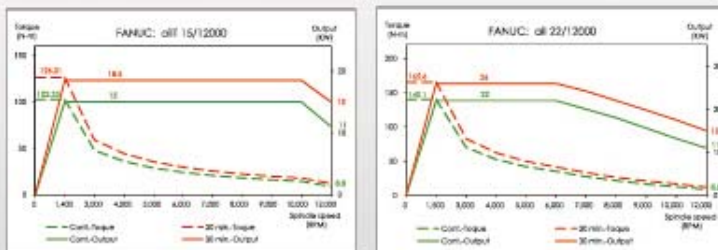
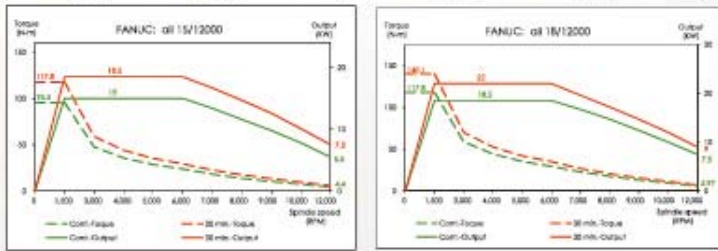
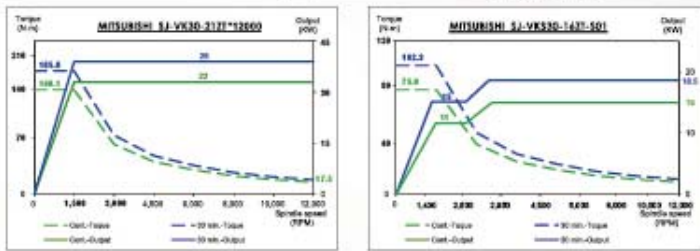
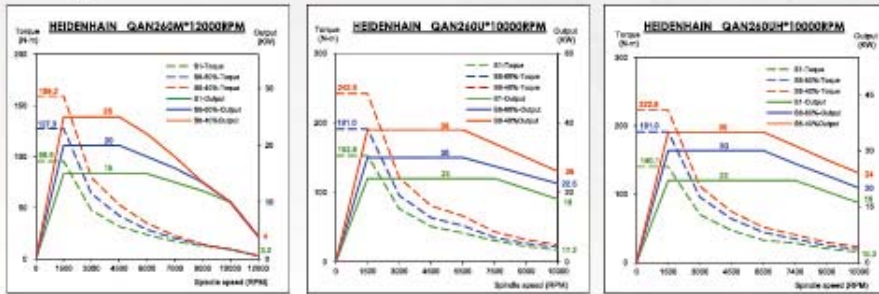

Gear type 6,000RPM

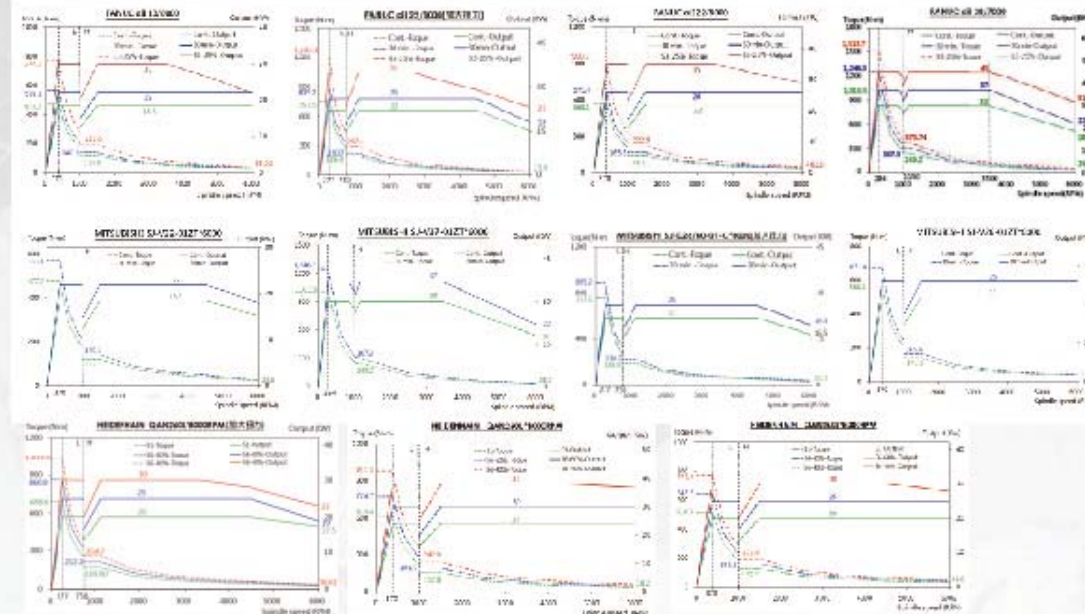

Gear type 8,000RPM

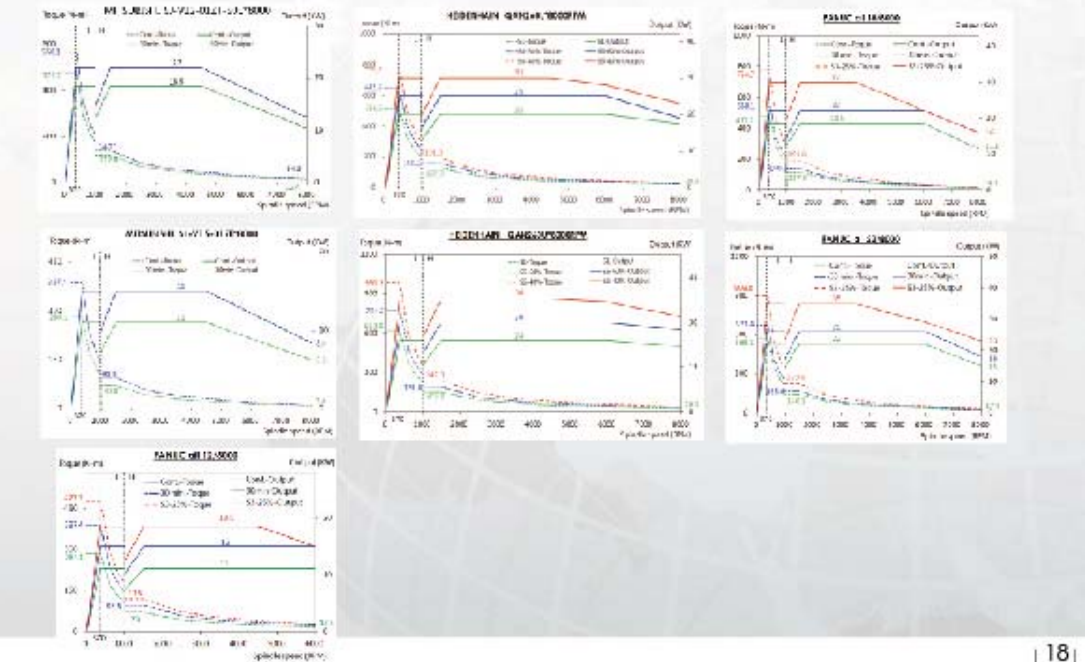

Machine Dimension

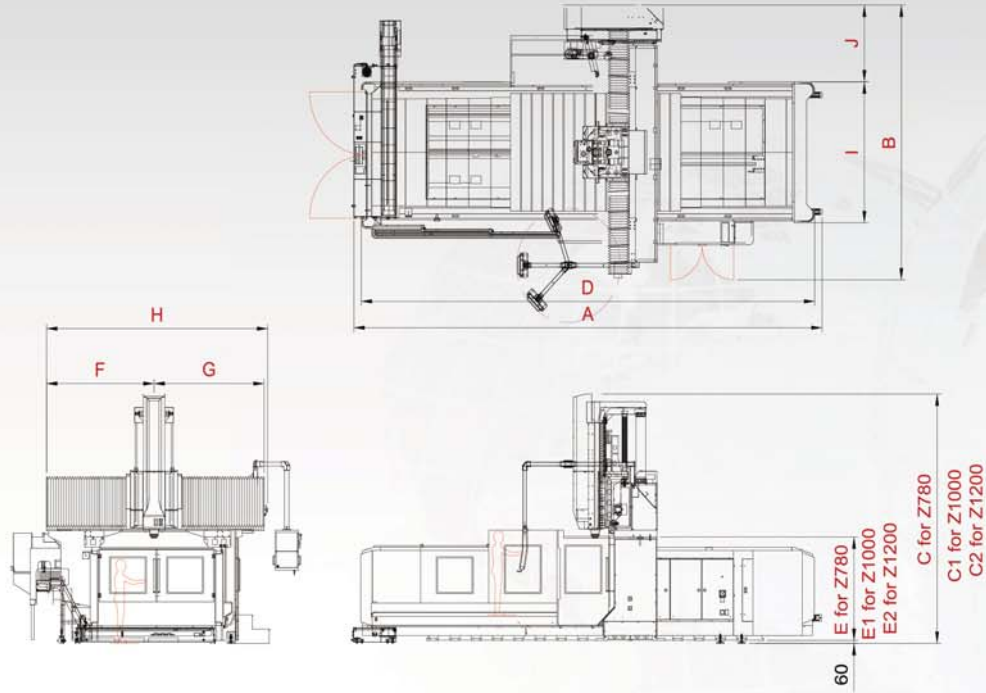

HSA-X20/X23/X27/X28/X32/X36 Series

Unit : mm

Model	A	B	C	C1	C2	D	E	E1	E2	F	G	H	I	J
HSA-320	9078	4955	4800/4900	5300	5700	8796	1900/2000	2200	2400	2125	2185	4394	2194	1630
HSA-420	11078	4955	4800/4900	5300	5700	10796	1900/2000	2200	2400	2125	2185	4394	2194	1630
HSA-323	9078	5255	4800/4900	5300	5700	8796	1900/2000	2200	2400	2200	2260	4579	2494	1630
HSA-423	11078	5255	4800/4900	5300	5700	10796	1900/2000	2200	2400	2200	2260	4579	2494	1630
HSA-523	13078	5255	4800/4900	5300	5700	12796	1900/2000	2200	2400	2200	2260	4579	2494	1630
HSA-327	9000	5840	4800/4900	5300	5700	8795	1900/2000	2200	2400	2525	2585	5195	2994	1630
HSA-427	11000	5840	4800/4900	5300	5700	10795	1900/2000	2200	2400	2525	2585	5195	2994	1630
HSA-527	13000	5840	4800/4900	5300	5700	12795	1900/2000	2200	2400	2525	2585	5195	2994	1630
HSA-627	15200	5840	4800/4900	5300	5700	14995	1900/2000	2200	2400	2525	2585	5195	2994	1630
HSA-428	11000	5840	4900	5300	5700	10795	2000	2200	2400	2525	2585	5195	2994	1630
HSA-528	13000	5840	4900	5300	5700	12795	2000	2200	2400	2525	2585	5195	2994	1630
HSA-532	13000	6240	4900	5300	5700	12795	2000	2200	2400	2750	2810	5670	3394	1630
HSA-632	15200	6240	4900	5300	5700	14995	2000	2200	2400	2750	2810	5670	3394	1630
HSA-536	13150	6740	4900	5300	5700	12945	2000	2200	2400	3025	3085	6195	3794	1730
HSA-636	15350	6740	4900	5300	5700	15145	2000	2200	2400	3025	3085	6195	3794	1730
HSA-736	17350	6740	4900	5300	5700	17145	2000	2200	2400	3025	3085	6195	3794	1730
HSA-836	19350	6740	4900	5300	5700	19145	2000	2200	2400	3025	3085	6195	3794	1730

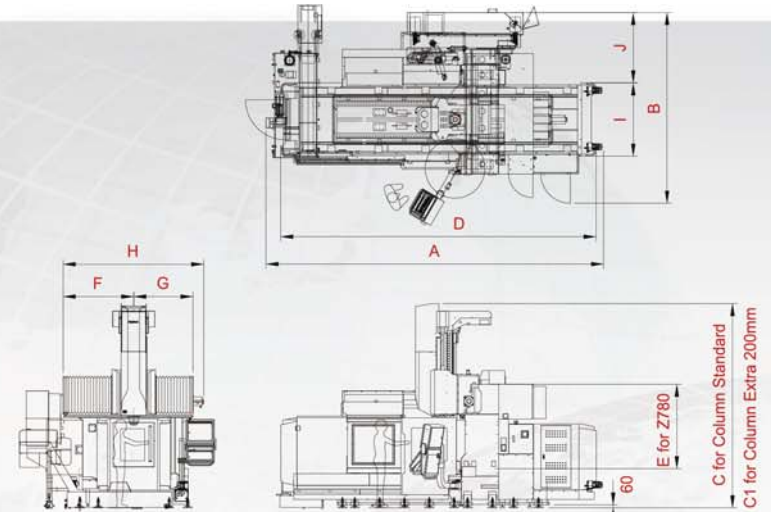

HSA-2212

Model	A	B	C	C1	D	E	F	G	H	I	J
HSA-2212	6800	3855	4120	4320	6355	1700	1423.5	1193.5	2832.5	1480	1425

unit : mm

HSA-X16

Model	A	B	C	C1	C2	C3	D	E	F	G	H	I	J
HSA-216	6682	4063	4338	4438	4538	5038	6266	1750	1733.5	1458.5	3379.5	1820	1413
HSA-316	9040	4063	4338	4438	4538	5038	8624	1750	1733.5	1458.5	3379.5	1820	1413

unit : mm

Mechanical Specifications Table

item	Model Unit	HSA-2212	HSA-216 / 316	HSA-320 / 420	HSA-323/423/523	HSA-327/427/527/627	HSA-428/528	HSA-532/632	HSA-536/636/736/836
Table	Working surface mm	2000 x 1100	2000 / 3000 x 1400	3000/ 4000 x 1800	3000 / 4000 / 5000x 2200	3000 / 4000 / 5000 / 6000 x 2200	4000 / 5000 x 2500	5000 / 6000 x 2500	5000 / 6000 / 7000 / 8000x 3000
	T-slot Width X pitch(number) mm	22 x 160 (6)	22 x 180 (7)	22 x 250 (11/11/15)	28 x 250 (11 / 15 / 19)	28 x 250 (11 / 15 / 19 / 23)	28 x 250 (15 / 19)	28 x 250 (19 / 23)	28 x 250 (19 / 23 / 27 / 31)
	Max. load (Average) kg	3500	8000 / 10000	10000 / 12000	10000 / 12000 / 15000	10000 / 12000 / 15000 / 18000	18000 / 20000	20000/23000	21000/24000 / 27000 / 30000
	X-axis travel mm	2250	2250 / 3250	3000 / 4000	3000 / 4000 / 5000	3000 / 4000 / 5000 / 6000	4000 / 5000	5000/6000	5000 / 6000 / 7000 / 8000
Travel	Y-axis travel mm	1200	1600 ; 1500(opt. for Z-axis box guideway)	2000	2300	2700	2800	3200	3600
	Z-axis travel mm	780	780	780 opt. 1000/1200	780 opt. 1000/1200	780 opt. 1000/1200	780 opt. 1000/1200	780 opt. 1000/1200	780 opt. 1000/1200
	Distance from spindle center to column mm	450	430	450	450	450	450	450	450
	Distance between two columns mm	1300	1600	2000	2300	2800	2800	3200	3600
Spindle	Distance from Spindle End to Table#50 mm	2780:120~900	2780:160~940 21000:140~1140	2780 : 200~980 21000 : 280~1280 21200 : 280~1480	2780 : 200~980 21000 : 280~1280 21200 : 280~1480	2780 : 200~980 21000 : 280~1280 21200 : 280~1480	2780:260~1040 21000:240~1240 21200:240~1440	2780:260~1040 21000:240~1240 21200:240~1440	2780:260~1040 21000:240~1240 21200:240~1440
	Distance from Spindle End to Table#40 mm	2780:180~960	2780:220~1000	2780 : 260~1040 21000 : 340~1340 21200 : 340~1540	2780 : 260~1040 21000 : 340~1340 21200 : 340~1540	2780 : 260~1040 21000 : 340~1340 21200 : 340~1540	—	—	—
	Spindle nose taper	#40 / #50	#40 / #50	#40 / #50	#40 / #50	#50	#50	#50	#50
	Spindle speed(DDS) rpm	10000 opt. 15000 only on #40	#40 10000 / 15000 / 20000 #50 10000 / 12000	#40 15000 / 20000 #50 10000 / 12000	#40 15000 / 20000 #50 10000 / 12000	10000 / 12000	10000 / 12000	10000 / 12000	10000 / 12000
Feed	Spindle speed(Gear) rpm	6000 only on #50 opt. 8000	#50 6000 / 8000	#50 6000 / 8000	#50 6000 / 8000	6000 / 8000	6000 / 8000	6000 / 8000	6000 / 8000
	Spindle speed(Built-in) rpm	—	—	#50 12000	#50 12000	12000	12000	12000	12000
Cutting feedrate (X / Y / Z) m/min	10/10/10	12/12/12 ; 12/12/7 (opt for Z-axis box guideway)	12/12/12	12/12/12(323) 10/12/12(423) 8/12/12(523)	12/12/12(327) 10/12/12(427) 8/12/12(527 / 627)	10/12/12(428) 8/12/12(528)	8/12/12 (532/632)	8/10/10(526/636/736) 6/10/10(836)	
	Rapid traverse rate (X / Y / Z) m/min	24/24/20	24/24/20 24/24/15 (opt. for Z-axis box guideway)	20/18/16	20/18/16(323/423) 14/18/16(527) 14/18/16(523)	20/18/16(327/427) 14/18/16(527) 10/18/16(627)	16 / 18 / 16(428) 12 / 18 / 16(528)	12/18/16(532) 10/18/16(632)	14/16/16(536) 12/16/16(636) 10/16/16(736) 8/16 / 16(836)
ATC	Capacity pcs	A: 24 opt. 32/40 only on #50	#40 A:32(40) ; #50 A:32(40/60) S:20	A : 32 / 40 / 60	A : 32 (40 / 60)	A : 32 / 40 / 60	A : 32 / 40 / 60	A : 32 / 40 / 60	A : 32 / 40 / 60
	Max. tool weight kg	#40: 7 #50: 18	#40: 7 #50: 18	#40 A: 7 #50 A: 20	#40 : 7 #50 : 20	A: 20	A: 20	A: 20	A: 20
	Tool shank	BT50(BBT40/BBT50/CAT40/CAT50/DIN)	BT-50 (CAT50/DIN/BBT50) BT-40 (CAT50/DIN/BBT40/HSK-A63)	#40 BT-40(CAT40/DIN/BBT40/HSK-A63) #50 BT-50(CAT50/DIN/BBT50)	#40 BT40(BBT40/CAT40/DIN69871A) #50 BT50(BBT50/CAT50/DIN69871A); HSK-A63(#40)	BT-50(BBT-50/CAT-50/DIN69871A)	BT-50(BBT-50/CAT-50/DIN69871A)	BT-50(BBT-50/CAT-50/DIN69871A)	BT-50(BBT-50/CAT-50/DIN69871A)
	Pull stub bolt	P50T-1/CAT-50/DIN, MAS-P40T-1/CAT-40/DIN	P40T-1 / P50T-1 (CAT-40/DIN 69872)	#40 P40T-1 #50 P50T-1	#40 MAS-P40T-1/DIN69872A(PD40TA) #50 MAS-P50T-1/DIN69872A(PD50TA)	MAS-P50T-1/DIN69872A(PD50TA)	MAS-P50T-1/DIN69872A(PD50TA)	MAS-P50T-1 / DIN69872A(PD50TA)	MAS-P50T-1/DIN69872A(PD50TA)
Motor	Max. tool size(dia.X length)#40 mm	75 x 300	∅ 75x 300L	A: ∅ 75x 300L	A: ∅ 75 x 300L x 7kg	—	—	—	—
	Max. tool size(dia.X length)#50 mm	110 x 350(24T) / 125 x 350(32T/40T)	∅125 x 300L	A : ∅125 x 300L	A : ∅125 x 400L x 20kg	∅125 x 400L x 20kg	∅125 x 400L x 20kg	∅125 x 400L x 20kg	∅125 x 400L x 20kg
Positioning Accuracy	Spindle drive motor (cont./30 min) kw	#40:11/7.5 #50:18.5/15(22/26)	#40 : 7.5/11 (opt.15/18.5) #50 : 15/18.5 (opt.18.5/22.2/26)	#40 : 7.5 / 11 opt.15 / 18.5 #50 : 18.5 / 22 opt. 22 / 26, 30 / 37	#40 : 11/7.5 DDS for Fanuc #50 : 22/18.5(18.5/15 DDS for Fanuc)	18.5 / 22 (15 / 18.5 DDS)	18.5 / 22 (15 / 18.5 DDS)	18.5 / 22 (15 / 18.5 DDS)	18.5 / 22 (15 / 18.5 DDS)
	3-axis laser positioning accuracy(JIS B6330), without linear scale								
	Positioning accuracy mm	±0.010	±0.010	±0.010	±0.010 / ±0.012 / ±0.012	±0.010 / ±0.012 / ±0.012	±0.012	±0.012	±0.012
	Repeatability mm	±0.003	±0.003	±0.003	±0.003	±0.003	±0.003	±0.003	±0.003
3-axis laser positioning accuracy(JIS B6330), with linear scale									
Positioning accuracy mm	±0.008	±0.008	±0.008	±0.008 / ±0.010 / ±0.010	±0.008 / ±0.010 / ±0.010	±0.010	±0.010	±0.010	
Repeatability mm	±0.003	±0.003	±0.003	±0.003	±0.003	±0.003	±0.003	±0.003	
3-axis laser positioning accuracy(VDI13441)repeat 5 time									
Positioning accuracy mm	0.015	0.015 / 0.016	0.016 / 0.018	0.016 / 0.018 / 0.026	0.016 / 0.018 / 0.026	0.018 / 0.026	0.026	0.026 / 0.028 / 0.028 / 0.030	
Repeatability mm	0.014	0.014	0.014 / 0.015	0.014 / 0.015 / 0.021	0.014 / 0.015 / 0.024	0.015 / 0.021	0.021	0.021 / 0.024 / 0.024 / 0.026	
Required air pressure kg/cm ²	6.5	6.5	6.5	6.5	6.5	6.5	6.5	6.5	
Electric power requirement KVA	#50 : 35-65 #40 : 25-60	45 / 50	40~75	40~75	40~75	40~75 (428 / 528)	45 - 70(532); 45-75(732)	45 - 75	
other	Machine weight kg	#50: 14720 #40:14720	18000 / 21000	2780 : 27500 / 30500 21000 : 28500 / 31500 21200 : 29500 / 32500	2780 : 30100 / 34100 / 38100 21000 : 31420 / 35420 / 39420 21200 : 32000 / 36200 / 40200	2780 : 33370 / 37370 / 45370 21000:34690 / 38690 / 46690 21200 : 35470 / 39470 / 47470	2780 : 39000 / 44000 21000 : 39500 / 44500 21200 : 40000 / 45000	2780 : 46000 21000 : 46500 21200 : 47000	2780 : 56000 / 62000 / 67000 / 72000 21000 : 56500 / 62500 / 67500 / 72500 21200 : 57000 / 63000 / 68000 / 73000
	Floor space mm	8535 x 5745	8630 / 10630 x 5880	11245 / 13245 x 6600	11415 / 13415 / 15415 x 6900	11650/13650/15650/17650 x 7500	13650 / 15650 x 7500	15744 x 7900	15200 / 17200 / 19200 / 21200 x 8450
	Machine dimension (L x W x H) mm	2780 : 6800 x 3855 x 4120	6712 / 9040 x 4619.5 x 4338(2780)	9080 / 11080 x 4955x4800(2780) (21000:HS300/21200:HS700)	9145 / 11145 / 13145 x 5255 x 4800(2780)	9077/11077/13077/15077 x 5914.5 x 4796(2780)	11077 / 13077 x 5610.5 x 4896 (2780)	2780 : 13105 / 15105 x 6300 x 4896	2780 : 13148 / 15148 / 17148 / 19148 x 6511 x 4896

VDI 3441 accuracy available upon order request.

※ According to standard machine for high precision mold machining industry, Z axis rapid traverse is 12000(mm/min)※